

SKYLAR

Bassinet & Bedside Sleeper

Owner's Manual

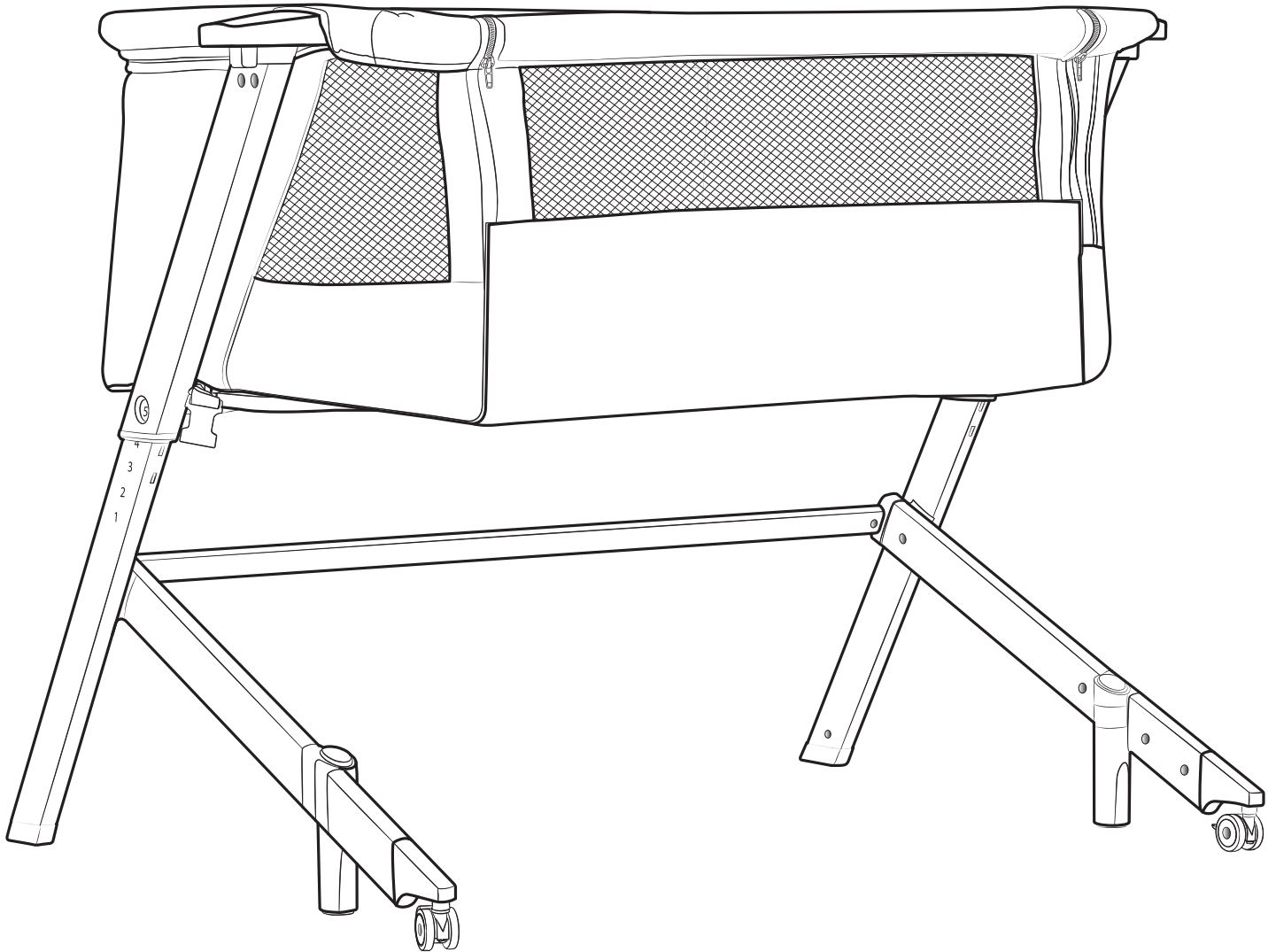

Scan the QR code to register your product
<https://dreamonme.com/customer-care/registration/>



Read all instructions before
assembling and using product.
IMPORTANT - Keep Instructions
for future use.



1121R1-387

WARNINGS

- Read all the instructions before assembling and using the product.
- Assemble product according to manufacturer's instructions for any of the uses (bedside sleeper or bassinet).
- **FAILURE TO FOLLOW THESE WARNINGS AND THE INSTRUCTIONS COULD RESULT IN SERIOUS INJURY OR DEATH. DO NOT USE THIS PRODUCT IF YOU CANNOT EXACTLY FOLLOW THE INSTRUCTIONS THAT COME WITH IT. THIS PRODUCT SHOULD BE FULLY ASSEMBLED PRIOR TO USE.**

SUFFOCATION HAZARD:

Infants have suffocated:

- In gaps between extra padding and side of the bassinet.
- On soft bedding. Use only the pad provided by Dream On Me, never add a pillow, comforter or any other mattress for padding.
- If a sheet is used with the pad, use only the one provided by Dream On Me or one specifically designed to fit the dimension of the mattress pad.
- Never leave the infant in the bassinet with sides down unless it is securely positioned in the sleeper mode attached to the adult bed with anchors securely in the place.
- To reduce the risk of SIDS, pediatricians recommend healthy infants to be placed on their backs to sleep, unless otherwise advised by your physician.

ENTRAPMENT HAZARD:

- To prevent death from entrapment, Bedside Sleeper must be properly secured to adult bed using the attachment system.
- There must be no more than 1/2 inch (13mm) gap between bedside sleeper and adult bed.
- Check tightness before each use by pulling bedside sleeper in a direction away from adult bed.
- If gap exceeds 1/2 inch (13mm) **DO NOT** use product. **DO NOT** fill the gap with pillows, blankets or other items that can cause suffocation.
- Always read and follow assembly instructions for each product use (bedside sleeper or bassinet)
- Please use **ALL** the required parts for each use (bedside sleeper or bassinet).

FALL HAZARD:

- A bassinet is designed to provide a sleeping area for an infant until he or she begins to push up on hands and knees or can roll over, or has reached 25lbs, whichever comes first, which is about 5 months of age.
- Please use all required parts for each use mode (bedside sleeper or bassinet).

WARNINGS (cont.)

- Check the instruction manual for a list of required parts.
- Periodically, check the product for loose, damaged, or missing parts. **DO NOT** use product if any part is loose or missing, or if there are any signs of damage. **DO NOT** substitute parts.
- Contact Dream On Me if replacement parts or instructions are needed.
- In Bassinet Mode, make sure that the side panel is locked.
- Strings can cause strangulation. **NEVER** place the product near window blinds or patio doors with cords where a child could reach the cord and be strangled, or hang strings over the product or place items with a string around an infant's neck or attach strings to toys.
- **DO NOT** place any cord or strap or similar items in or near this product that could be wrapped around a child's neck.
- Strings can cause strangulation. **DO NOT** place anything with a string around a child's neck, such as hood strings or pacifier cords. **DO NOT** suspend strings over a bassinet or cradle or attach strings to toys.

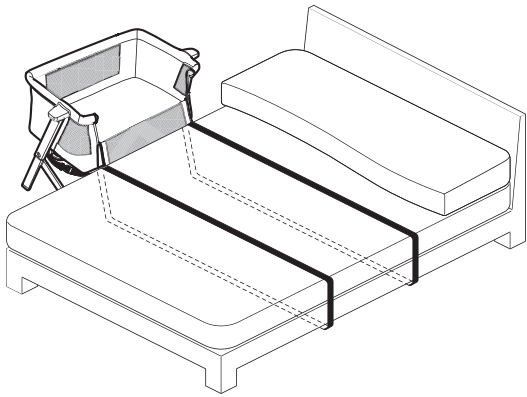

NEVER use this product in bedside sleeper mode without fixing buckles securely attached to the bed.

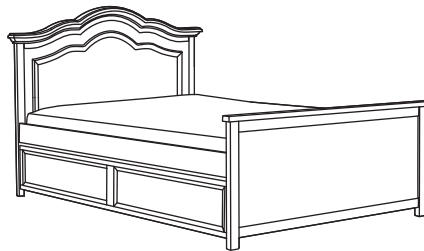

Acceptable bed frame in-line.

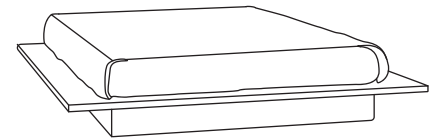

Non-acceptable bed frame not in-line.

SUFFOCATION, ENTRAPMENT AND FALL HAZARDS:

- To use the bassinet mode, **ALWAYS** raise the side with the zipper to completely close up all 4 sides.
- **ALWAYS** push adult mattress against bedside sleeper after securing to the bed with safety strap and fixing the buckles.
- **NEVER** leave the infant in bassinet with the sides down.
- The bedside sleeper is designed for use with adult beds that are between 18.5-24 inches (47-60 cm) from floor to top of adult mattress.

WARNINGS (cont.)

- Fixing or attaching the buckles and straps to adult bed must **ALWAYS** be done in bedside sleeper mode. Product in bedside sleeper mode must be tightly attached to adult bed mattress to ensure safe use.
- It is recommended to make the straps shorter than the width of the mattress to ensure bedside sleeper is pressed securely and tightly against the adult bed, without any gaps.
- A bedside sleeper is designed to provide a sleeping area for an infant until he or she begins to push up on hands and knees or can roll over, or has reached 25lbs, whichever comes first. Move your child to another sleeping product when your child reaches this stage.
- **DO NOT** use the bedside sleeper if any parts are missing, damaged, or broken. Contact Dream On Me for replacement parts and instructions.
- **DO NOT** substitute parts.

IMPORTANT FOR THE SAFETY OF YOUR CHILD

Co-Sleep Mode (Fixing to the Bed)

This method is only compatible with bed types that comply with all of the conditions described here:

- The side support of the bedside sleeper should always be placed close to the adult mattress.
- The mattress should always be aligned with the height of the side support of the co-sleeper.
- The bedside sleeper should be firmly fixed to the structure of the adult bed or to the mattress support.
- Check to make sure that the bedside sleeper in the bedside sleeper mode does not interfere with the adult bed.
- During use, make sure that the adult bed sheets, blankets etc, do not enter the bedside sleeper and cover the interior of the bedside sleeper. This can cause suffocation.
- In the bedside sleeper mode, the two legs of the bedside sleeper should always be adjusted to the same height
- Ensure that the fixing buckles are straight and not loose.
- When the bedside sleeper is attached/tied to the bed, that the actual bassinet must remain straight and not lopsided. If the bassinet is not straight/flat, contact our customer service immediately for help.
- The attachment must always be used in bedside sleeper mode.
- During the removal/or application of the lining, handle the fabric carefully in order to avoid accidental damage or tears.

WARNINGS (cont.)

- Before every use, check to make sure that there is no space between the adult mattress and the side of the bedside sleeper. If there is, pull the belts firmly to tighten until there's no space.
- Use of the product is only permitted for bed or mattress with straight sides. Do not use the product with a round mattress or a water bed.
- When the product is used in the bedside sleeper mode, it should always be fitted to the long side of the bed. Do not fix the product to the short side of the bed.
- The removal and/or application operations may take a few minutes and should be carried out by adult.
- When in bassinet mode, the adjustable feet should always be extended to their full length.

THANK YOU...

.... for choosing **Dream On Me** and congratulations on joining our family;
a family that has been transforming lives for 30 years!

We appreciate your feedback and wish you the very best in the coming years with your new addition. If you have any questions or concerns please don't hesitate to reach out to us. One of our trusted Customer Care representatives will be happy to assist you.

Thank you again for entrusting us to supply you with safe and affordable baby products and accessories.

PARTS

If there are any missing parts, please contact **Dream On Me** before using the product.

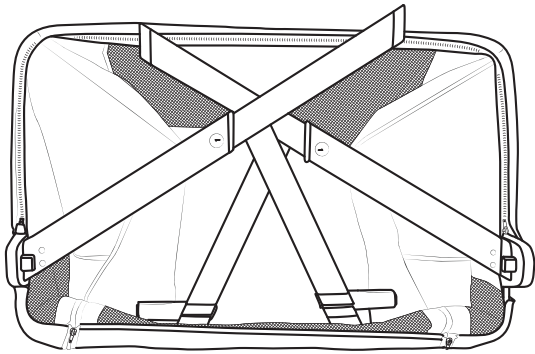

A Frame, Legs and Fabric

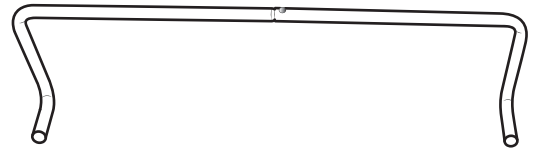

B Side Rail (x1)

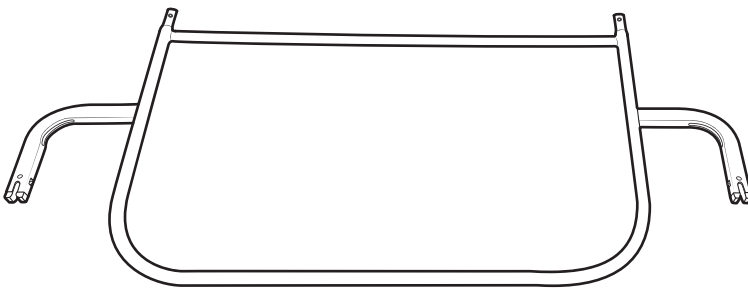

C Middle Support Frame (x1)

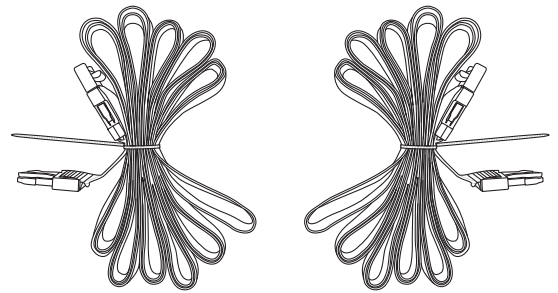

D Fixing Belts (x2)

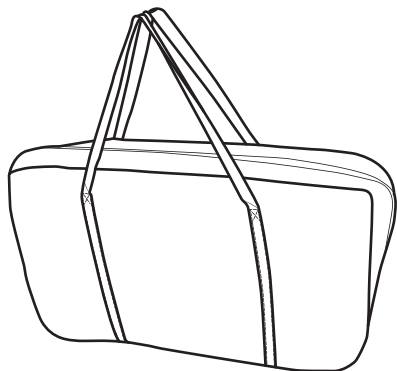

E Travel Bag (x1)

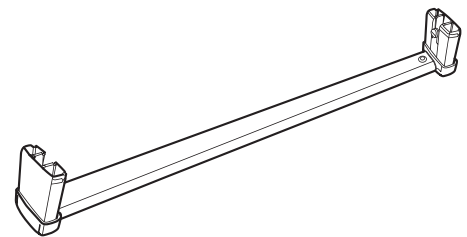

F Stabilizing Bar (x1)

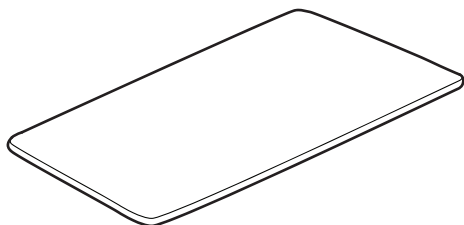

G Mattress Pad

ASSEMBLY DETAILS

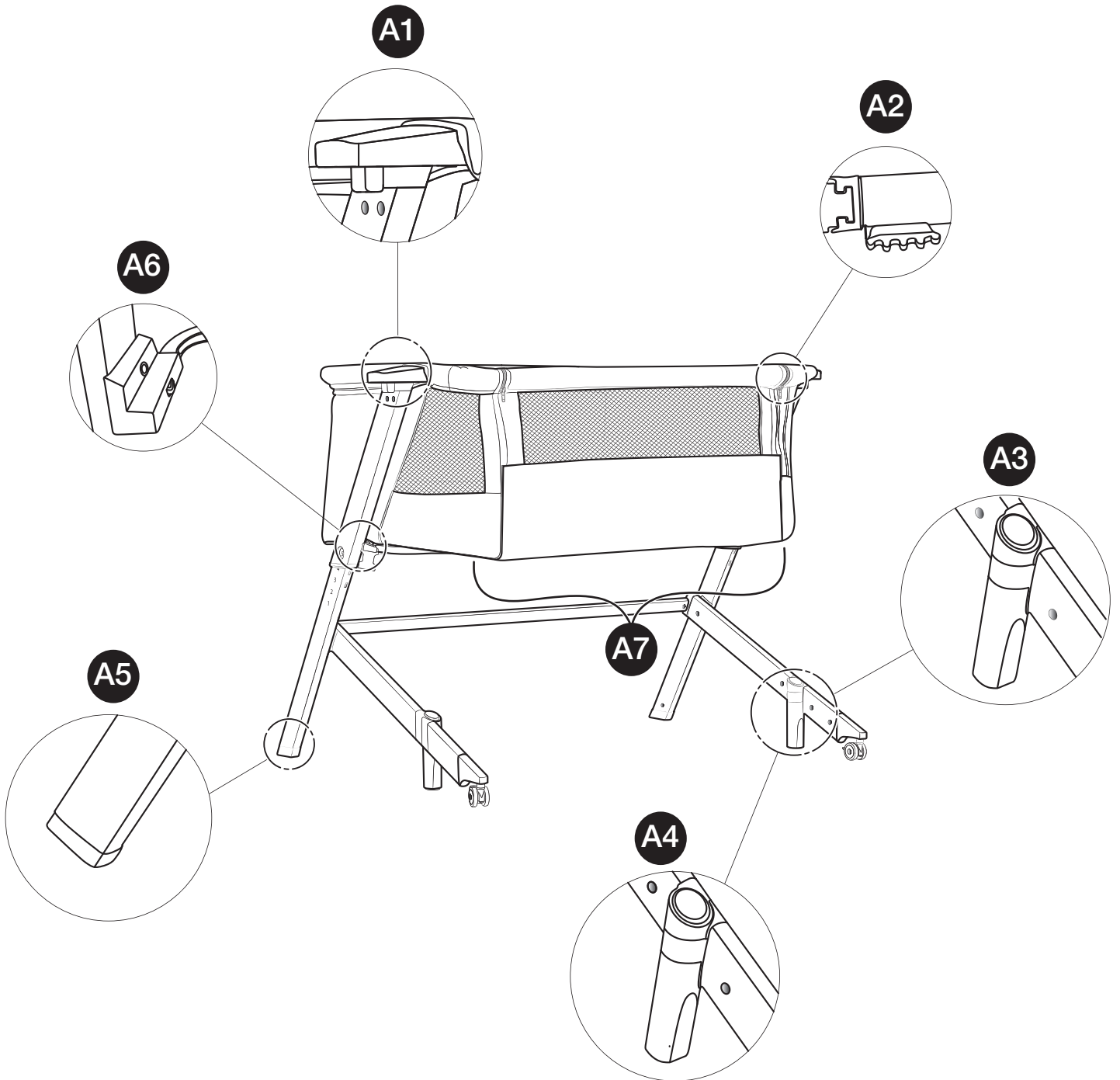

A1. Height adjuster button

A3. Adjustable feet

A5. Non-slip feet

A7. Fabric lining

A2. Bar Lock Lever

A4. Adjustable feet rotate button

A6. Middle support frame release button

BASSINET ASSEMBLY

1

1a. Insert the Side Rail (B) into the Middle Support Frame (C) by lining up the buttons and holes until it clicks into place as shown in the diagram.

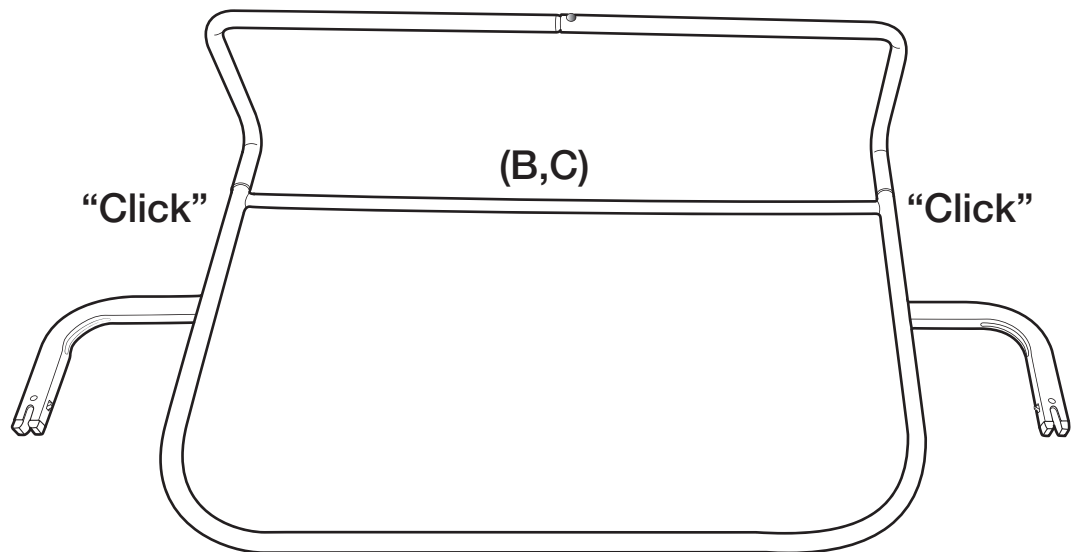
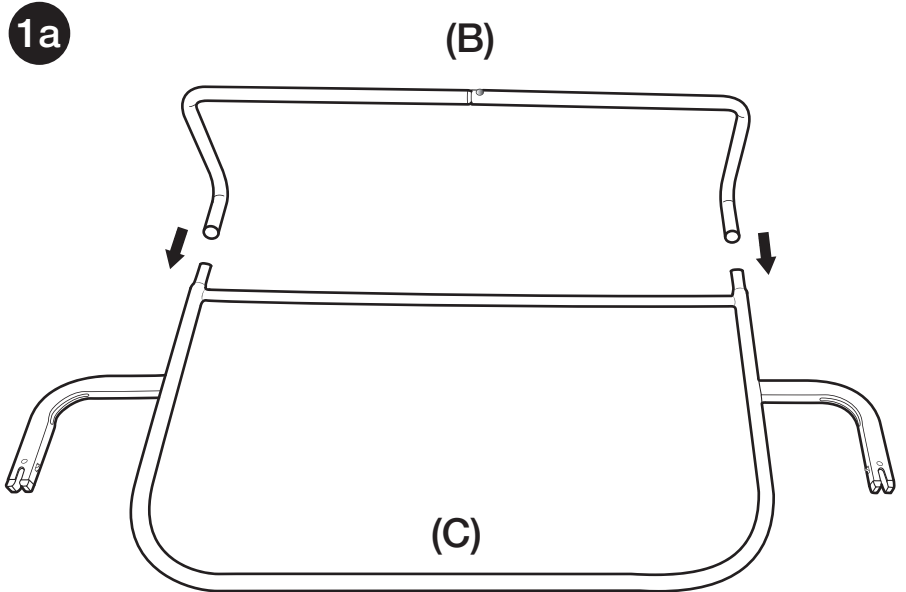

BASSINET ASSEMBLY

2

- 2a. Locate the part labelled as (A6) in the image. Insert the sides of Middle Support Frame (C) into the part (A6) on both the sides.
- 2b. Gently push it into the side slots (A6) until it clicks into place as shown. Also, make sure that the side rail (B) is facing upward as shown in the diagram.

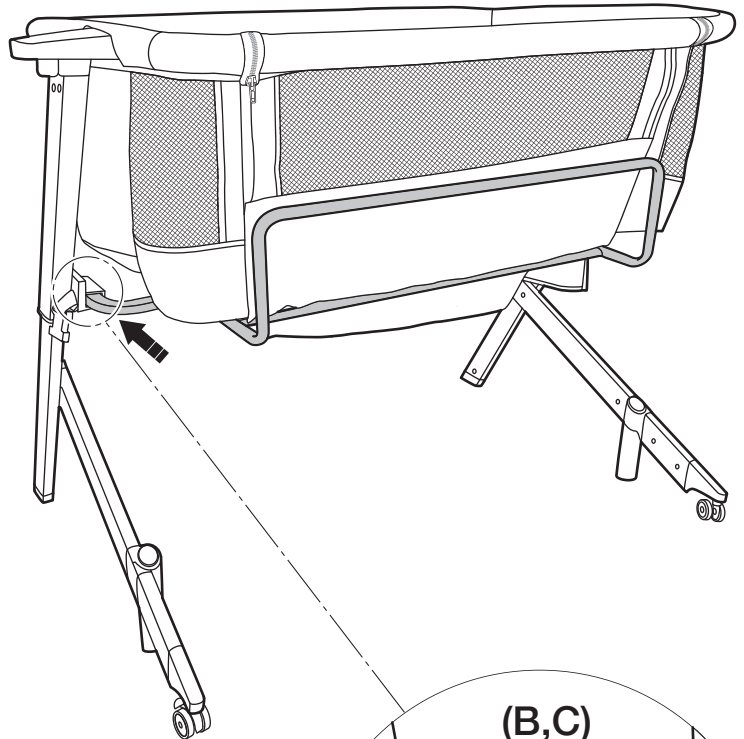

2a

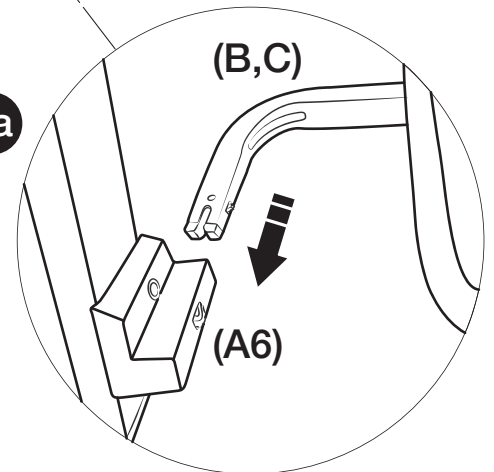

2b

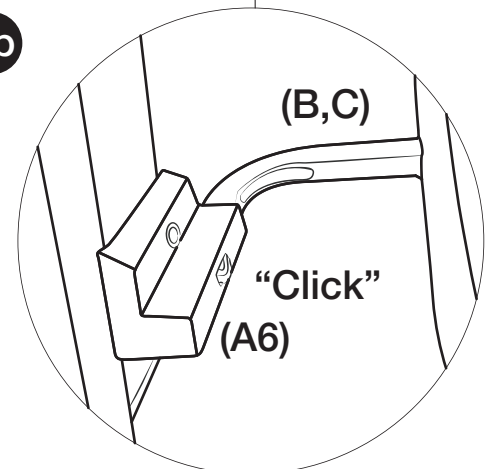

BASSINET ASSEMBLY

3

- 3a. Locate the tube slots on both sides, insert the Stabilizing Bar (F) and push until it clicks into place as shown in the diagram.

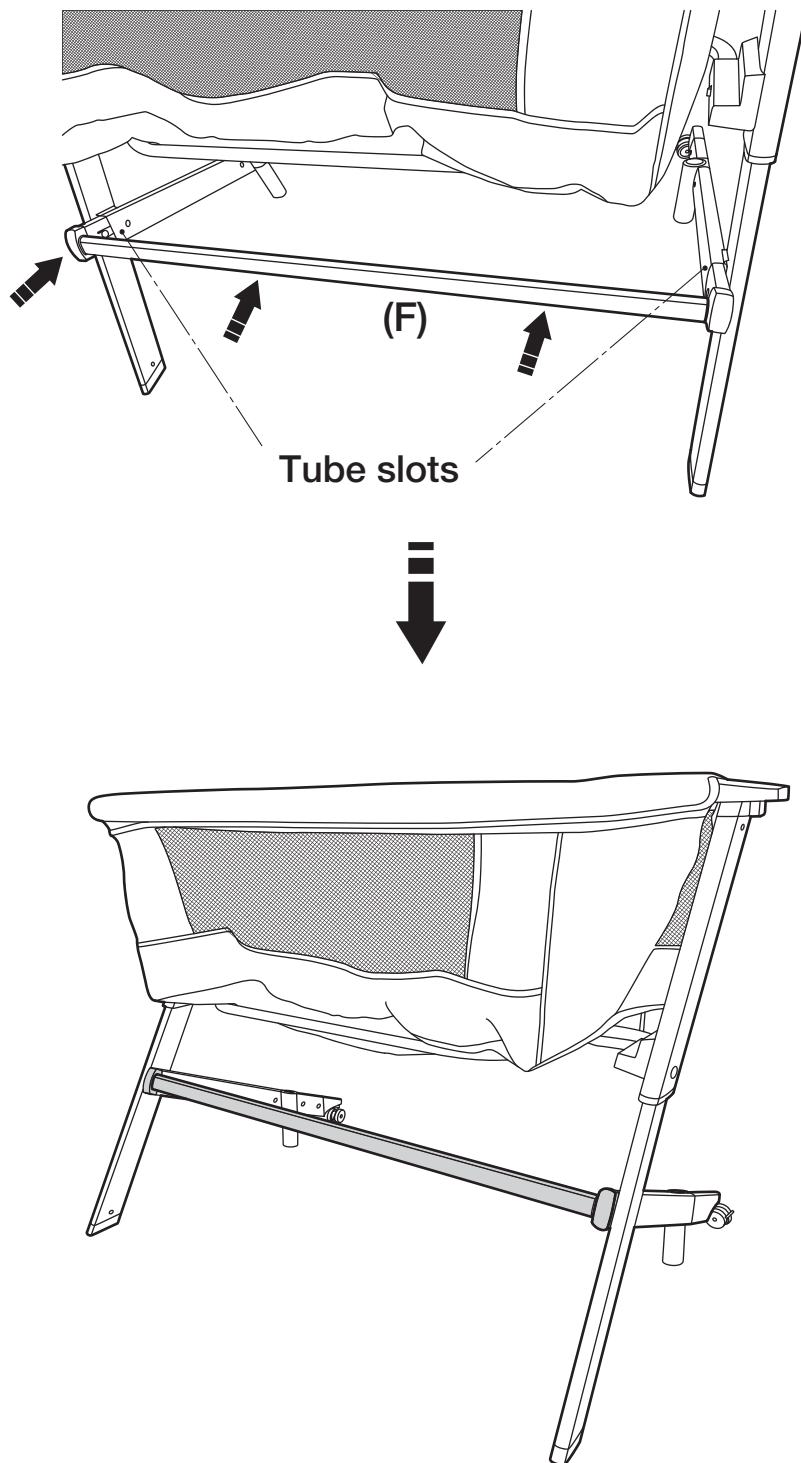

BASSINET ASSEMBLY

4

- 4a. Locate the 5 loops of the fabric and velcro the loops underneath the Fabric Lining (A7) as shown.

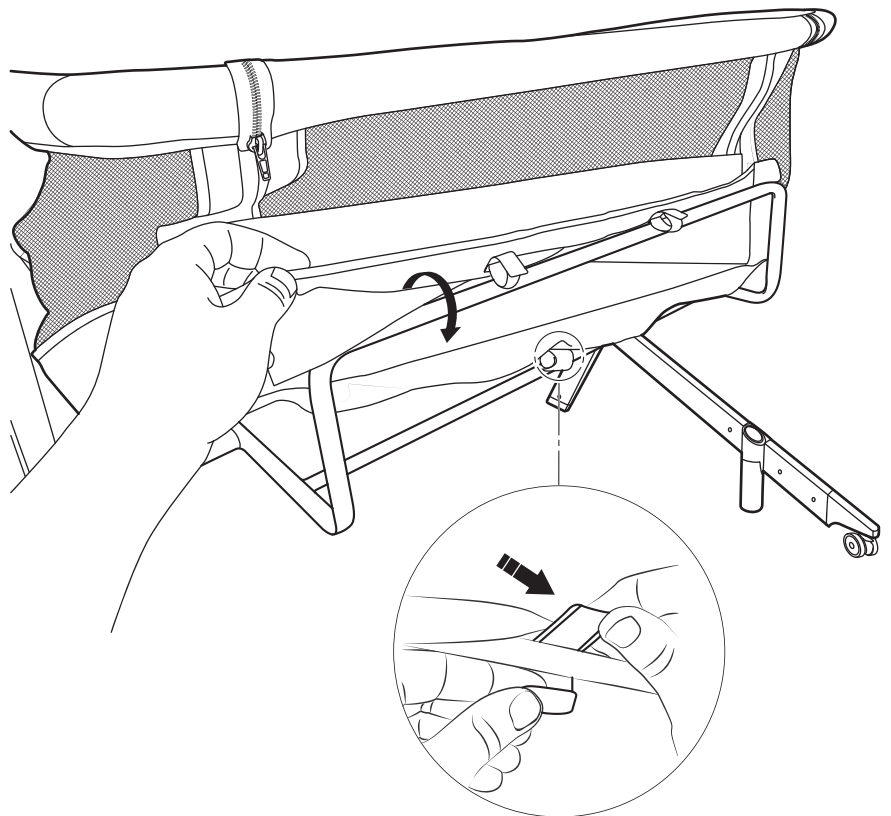
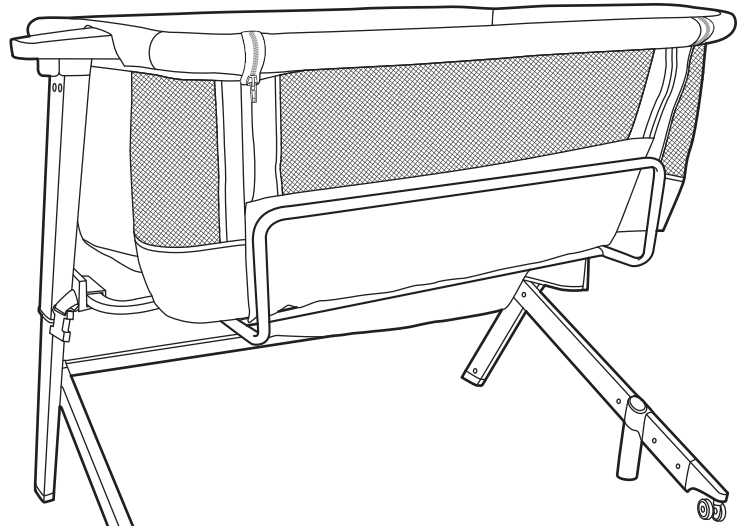

BASSINET ASSEMBLY

5

5a. Locate the 2 remaining loops underneath the bassinet and velcro them to the middle support Frame (C).

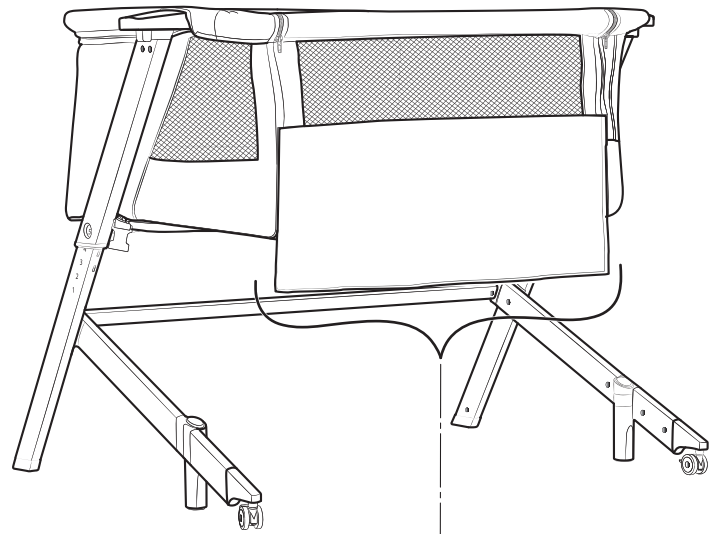

5a

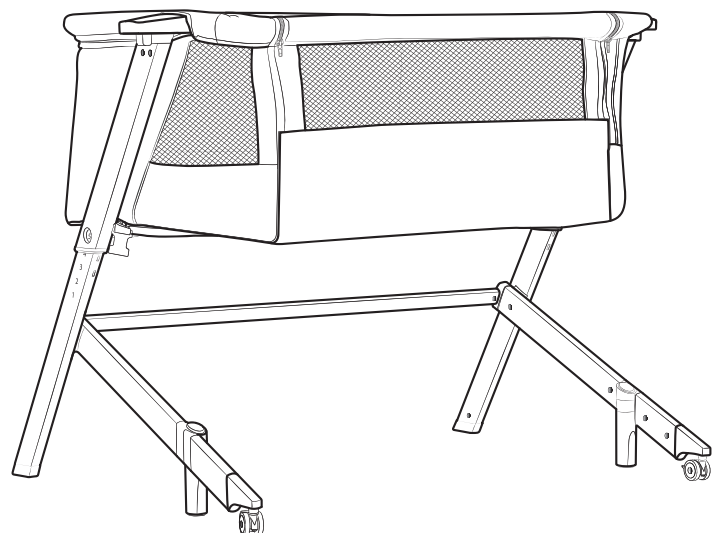
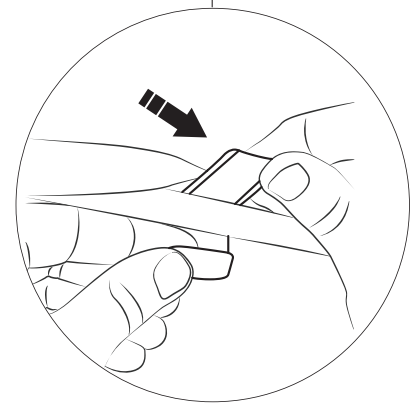

BASSINET ASSEMBLY

6

6a. Place the Mattress Pad (G) into the bedside sleeper.

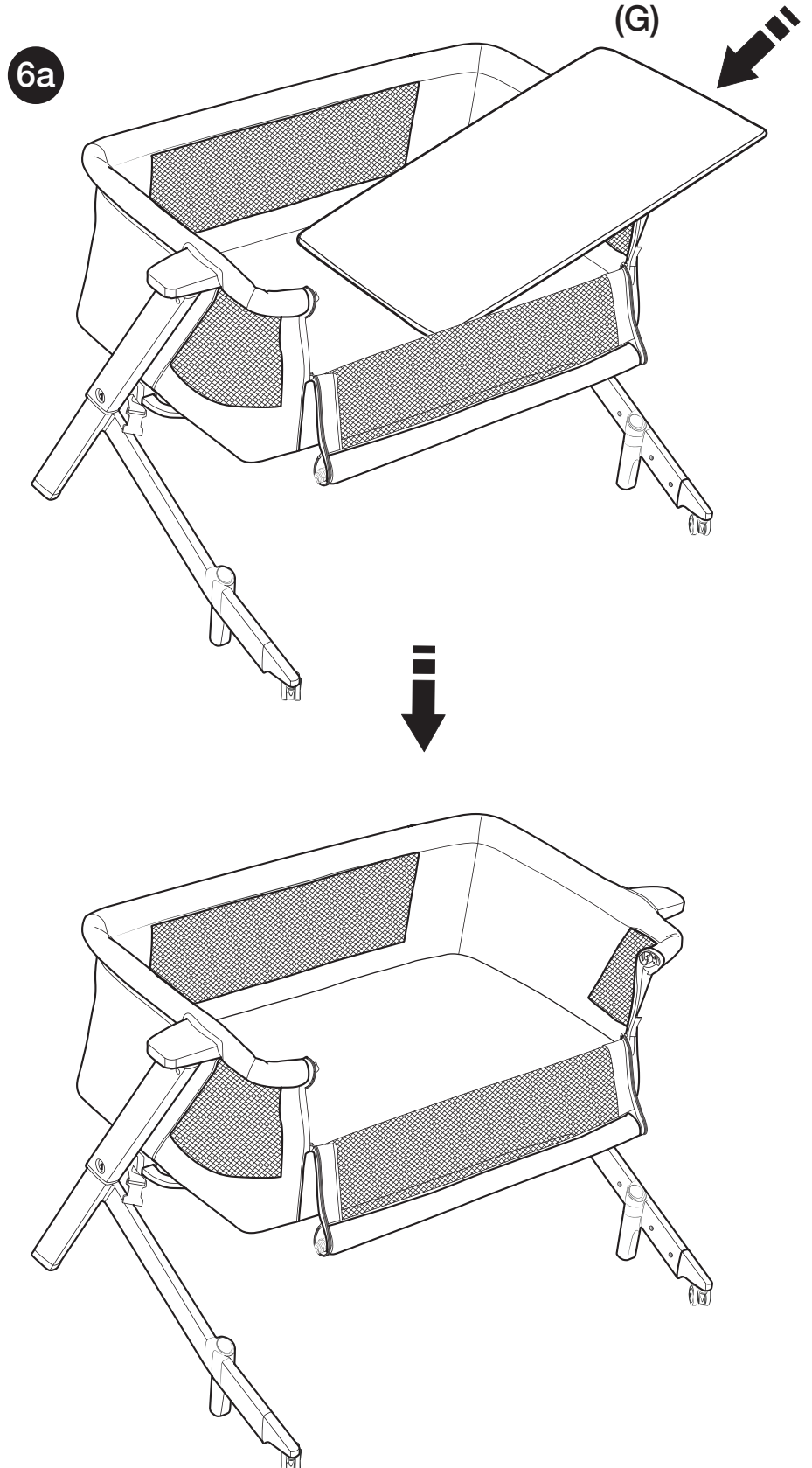

HEIGHT ADJUSTMENT AND ROTATION OF FEET

1. To raise or lower the bassinet, press the height adjustment buttons (A1) on both sides of the bassinet together.
2. Ensure that both the legs of bassinet are of same height. The base should NEVER be inclined.
3. Rotate the adjustable feet inwards as shown in the diagram to make sure the bedside sleeper is closer to the parent's bed in case the bed used is a box bed.

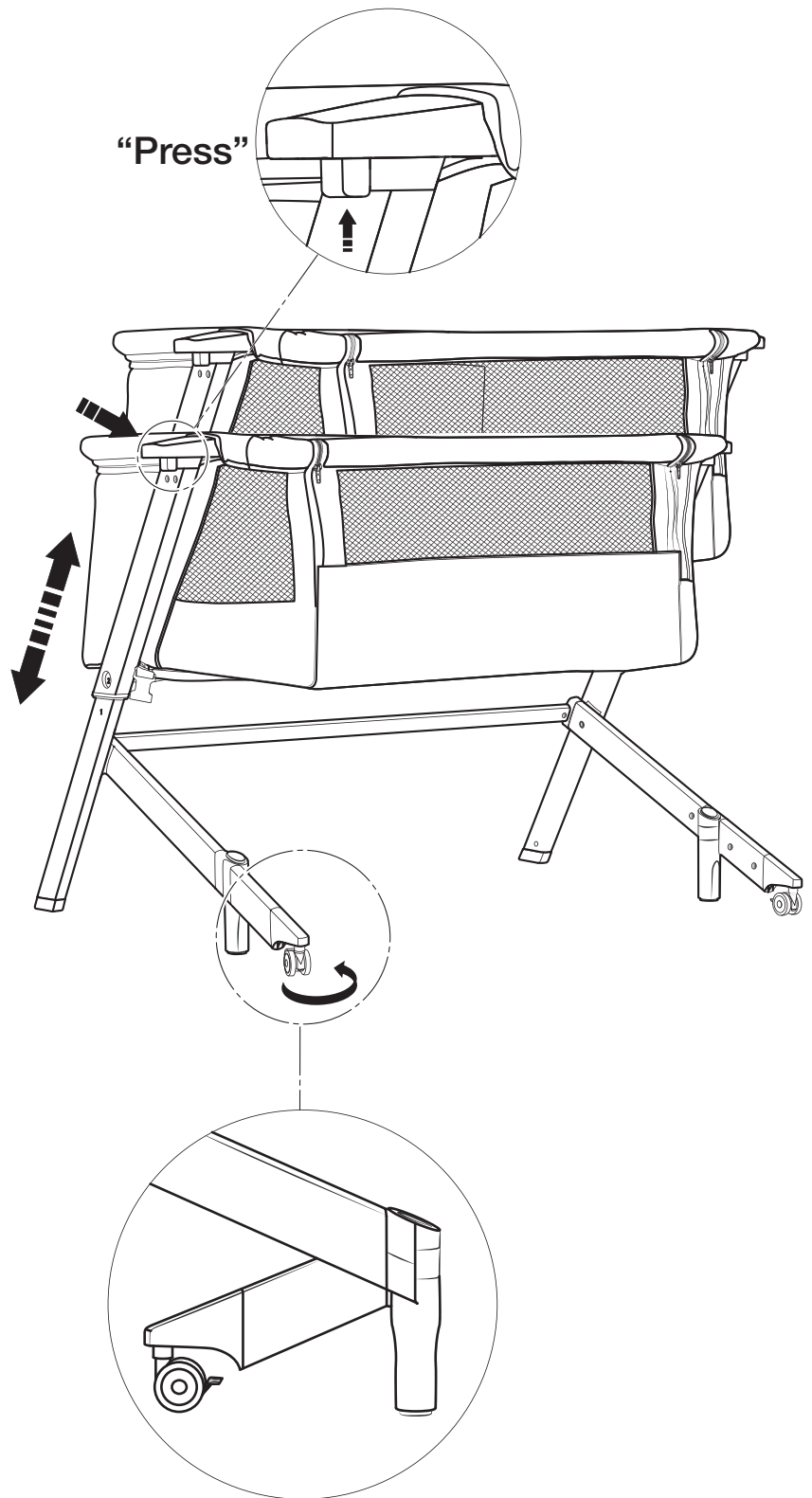

BEDSIDE SLEEPER MODE

1

- 1a. To use bassinet as a bedside sleeper, unzip the sides of the bedside sleeper completely.
- 1b. Slide the bar lock lever on the top bar and lift the top bar out of the grooves on both sides.

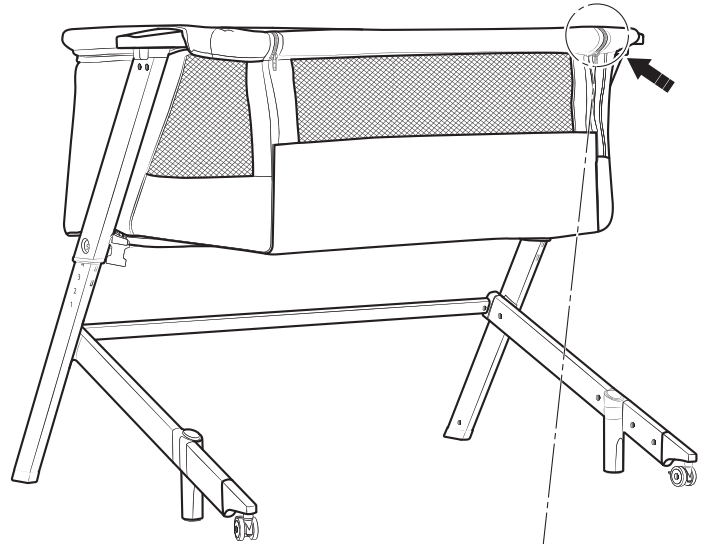

1a

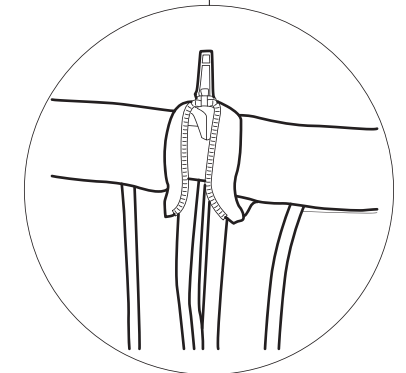
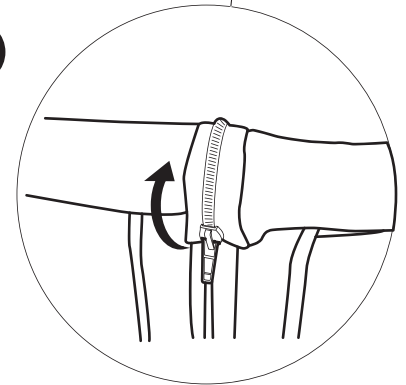

Top Bar

1b

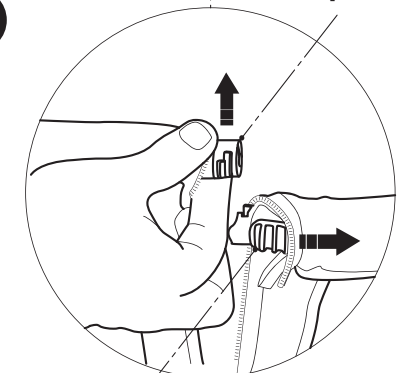

Bar Lock Lever

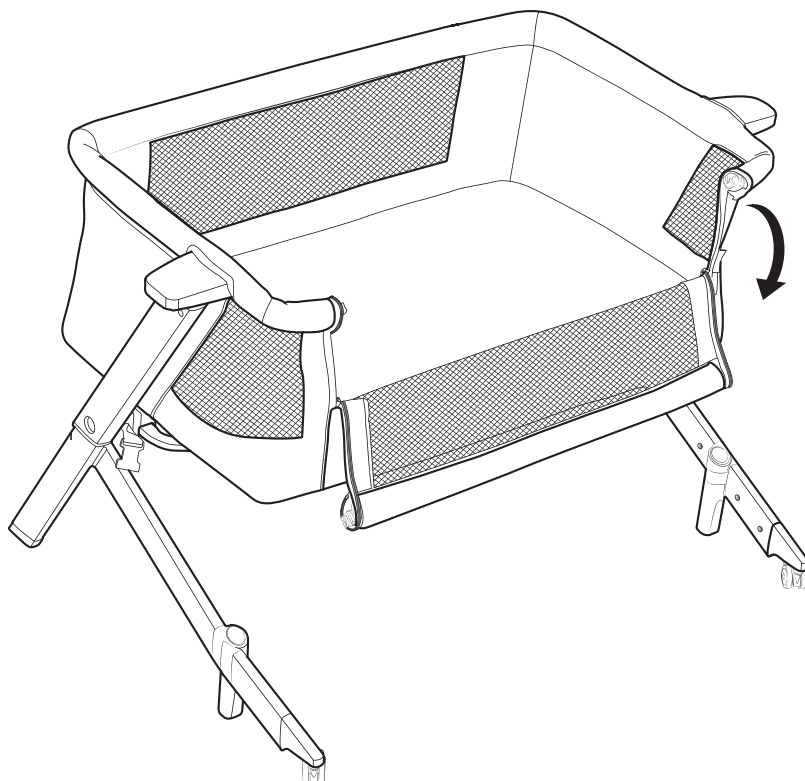

BEDSIDE SLEEPER MODE

2

- 2a. Move the bedside sleeper closer to parents' bed to check the height of bedside sleeper. The unzipped side of bedside sleeper should always be closer to the mattress. The mattress should be always aligned to the bedside sleeper.
- 2b. To avoid injury from the infant's neck being caught on the top rail on the side that is next to the parent's bed, the top rail must be no higher than parent's bed mattress.
- 2c. Pass the Fixing Belt (D) under the bed to the other side and pass it above the mattress by pulling belts firmly until the straps are in correct position as shown in the diagram. Tighten the Harness of the Fixing Belt (D) until it clicks into the place.
- 2d. Rotate the adjustable feet inwards as shown in the diagram to make sure the bedside sleeper is closer to the parent's bed in case the bed used is a box bed.

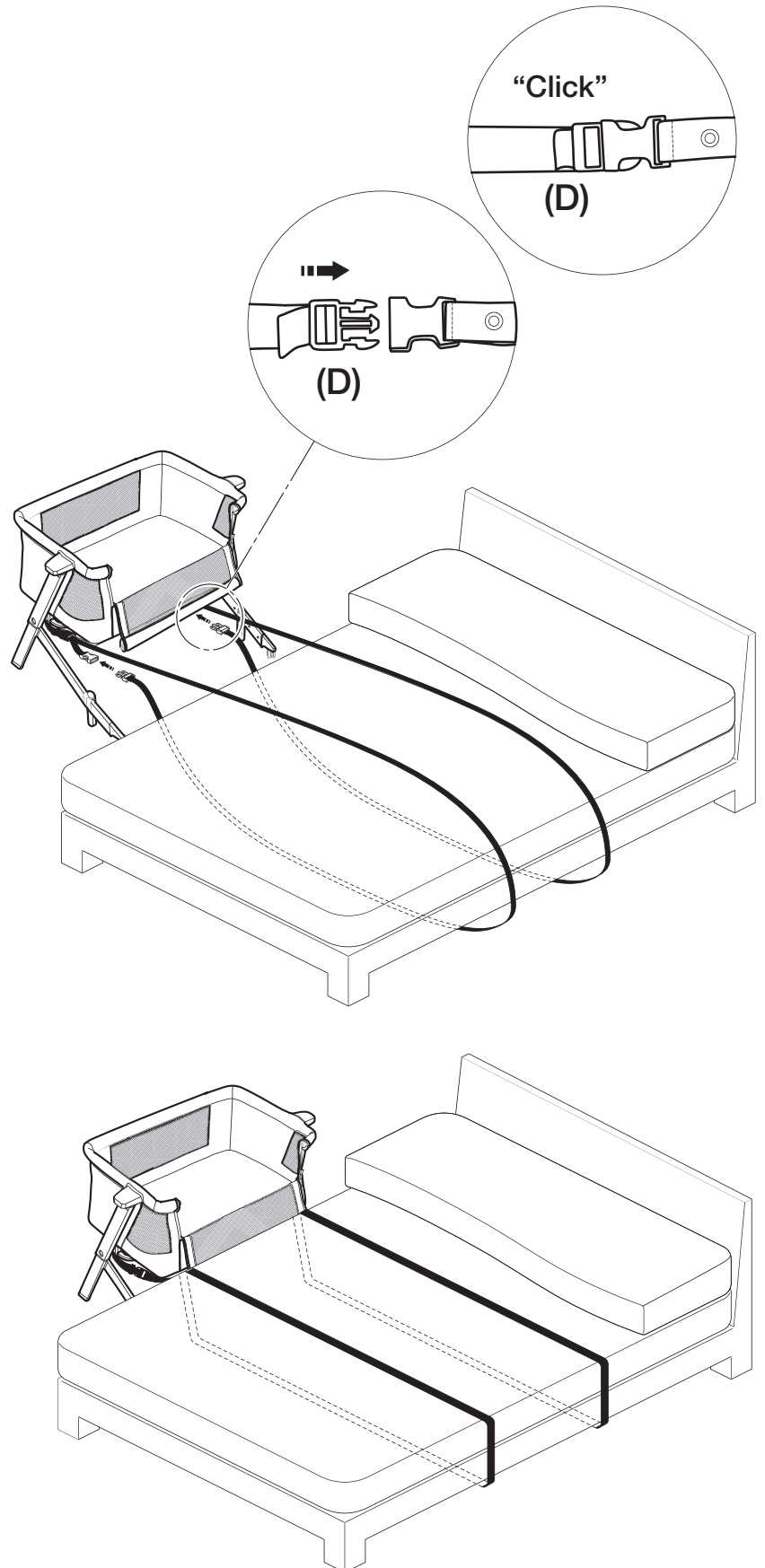

TRAVEL MODE

1. To fold and store the bassinet, remove parts Side Rail (B), Fixing belt (D), Stabilizing Bar (F) and Middle Support Frame (C) and adjust at the lowest position.
2. Place the mattress pad (G) on the floor and place the Stabilizing Bar (F) diagonally across as shown in diagram.
3. Next, fold the Frame, legs and fabric (A) and place it on top of the mattress pad (G) and Stabilizing Bar (F) as shown.
4. Next, place the parts Side Rail (B) and Middle Frame (C) as depicted in the diagram.
5. Next, stick the product into the Travel Bag (E).

2

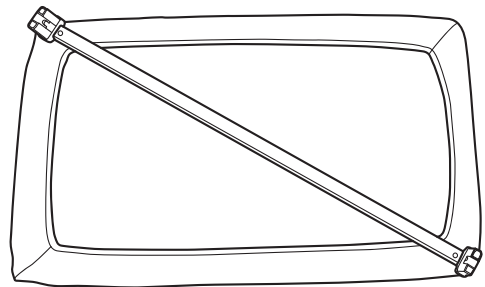

3

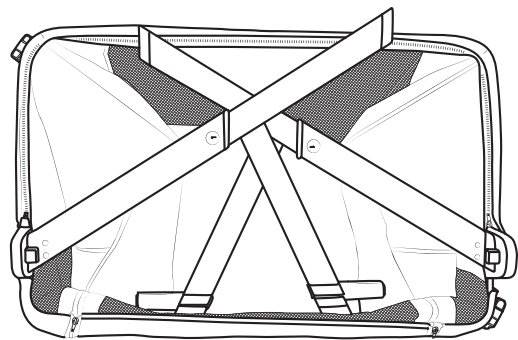

4

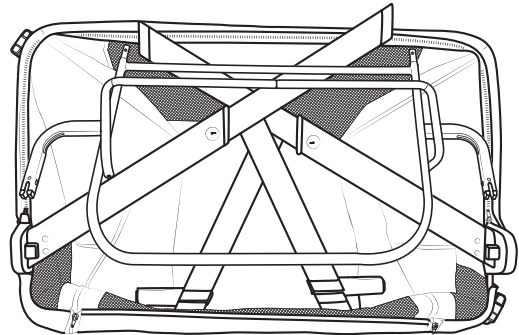

5

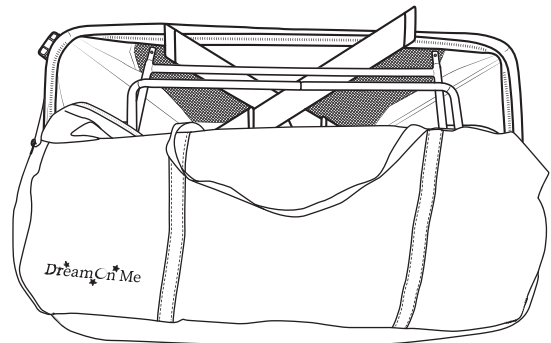

SAFETY

1. The bedside sleeper is designed for use with adult beds that are between 18.5 - 24 inches (47 - 60 cm) from floor to top of adult mattress.
2. **NEVER** use this product in bedside sleeper mode without fixing or attaching the buckles securely to the adult bed. Lock the wheels in place.

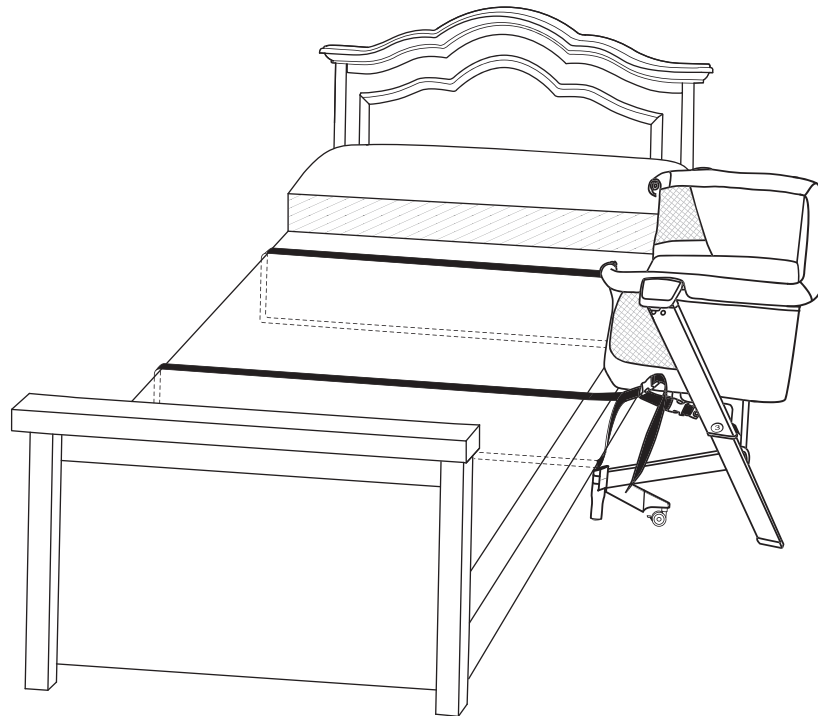
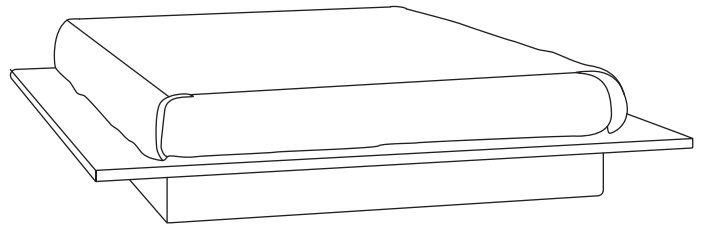
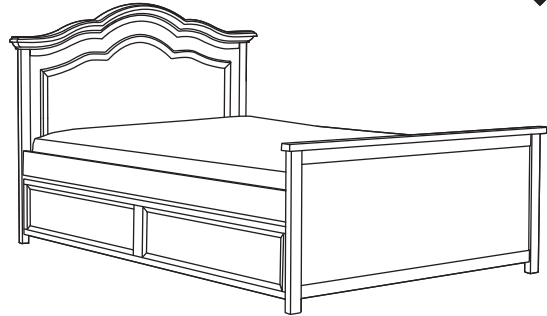

CARE AND CLEANING

1. Remove the mattress pad and release all the velcro loops attached to the bassinet.
2. Unzip the zipper underneath the fabric lip on the top frame. Pay attention not to damage the fabric.

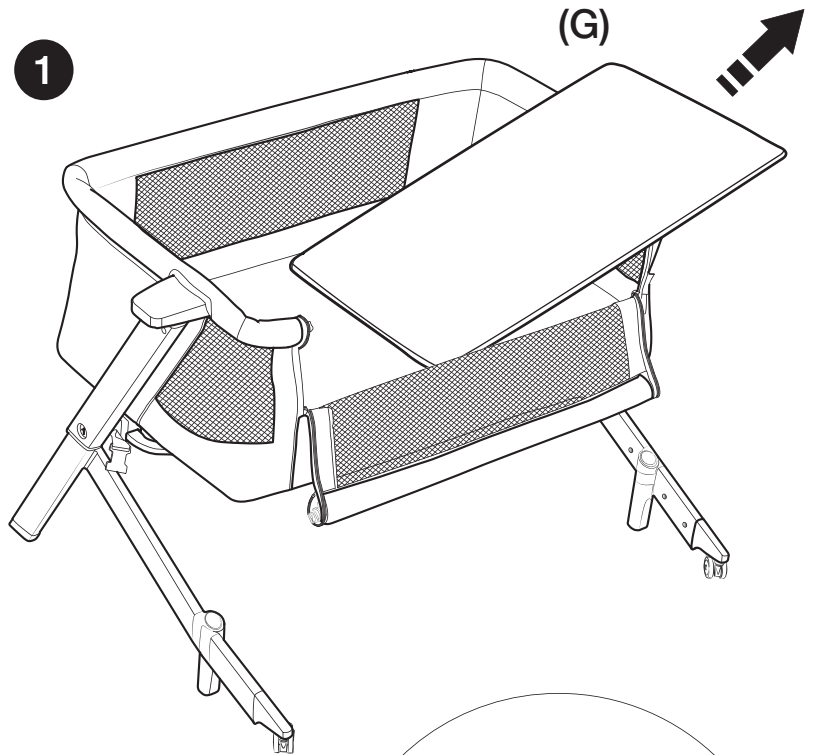

2

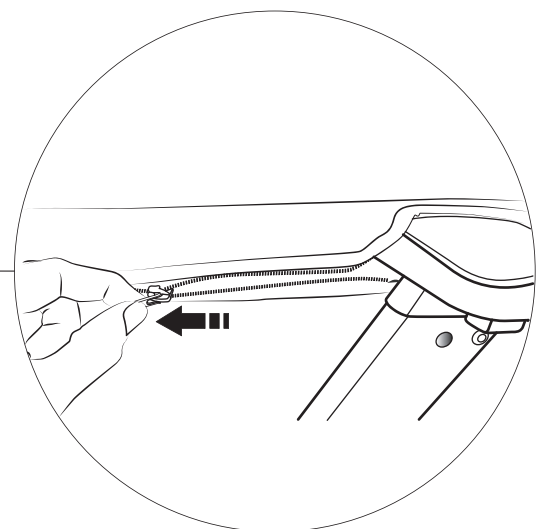
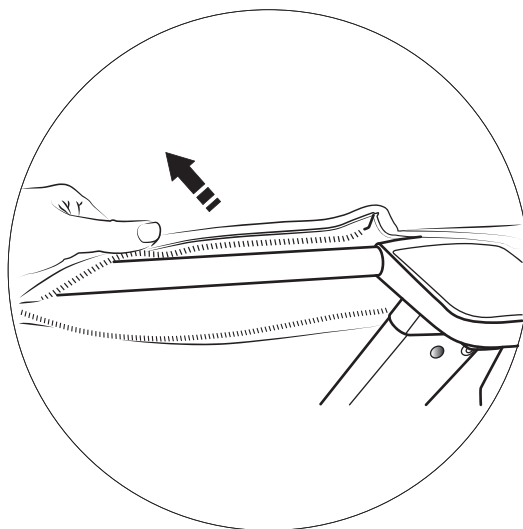
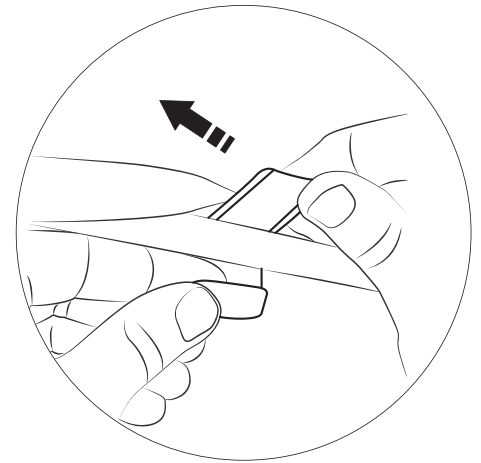

MAINTENANCE

- The product has a water resistant fabric cover which is completely removable and washable.
- The removal/application activities should only. On a regular basis, check the condition of the product for any possible damage. In case of damage, do not use it and keep it out of the reach of children.
- For washing of the fabric, carefully comply with instructions indicated on the label.
- For cleaning, do not use solvents, abrasive or aggressive products.
- After each wash, check the resistance of the fabric and of the stitching.



Hand wash in cold water



Do not bleach



Do not tumble dry



Do not iron



Do not dry clean

YOU DID IT!

It's time to make a happy sleep for your little one in this sturdy, multi-tasking and stylish Bassinet!



1532, S. Washington Avenue
Piscataway, NJ 08854
E-mail: info@dreamonme.com

www.dreamonme.com

Follow us on

 [@dreamonmeinc](https://www.facebook.com/dreamonmeinc)  [@dreamonmeinc](https://www.instagram.com/dreamonmeinc)

to get your nursery featured on our social media.

Enter our monthly giveaway!

Simply scan the QRcode to register.



Chat with us!

For any questions or concerns or feedback.



DOM
FAMILY

