

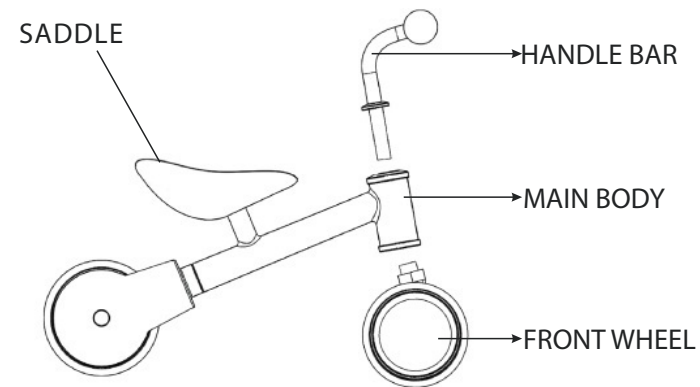

ITEM NO.: #363

## Parts



## ASSEMBLY INSTRUCTION

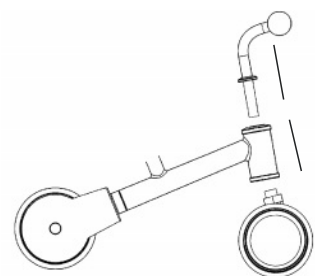

STEP 1

1. INSTALL THE HANDLE BAR AND FRONT WHEEL TO THE MAIN BODY AS THE STEP 1

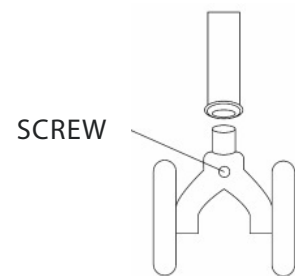

STEP 2

2. PAY ATTENTION ON THE FRONT FORK DIRECTION, THE SCREW IS IN THE FRONT AS STEP 2

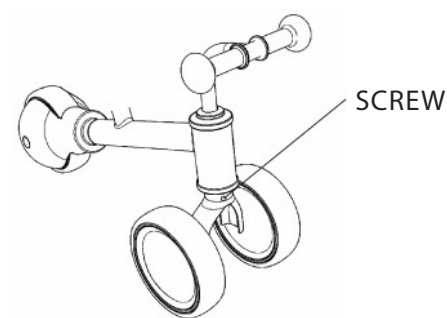

STEP 3

3. FIX THE SCREW BY INNER HEXAGON SPANNER

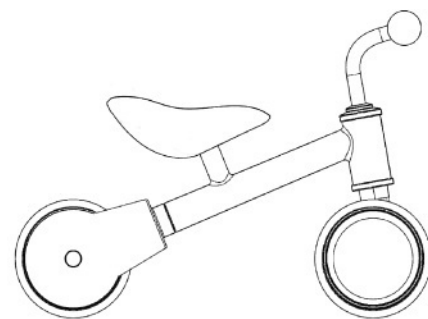

STEP 4

4. INSERT THE SADDLE AND FIX THE SCREW BY INNER HEXAGON SPANNER.

**WARNING!** Protective equipment should be worn. Not to be used in traffic

- 1) The walking bike should be assembled by adults only.
- 2) Before use, make sure that the walking bike is properly assembled.
- 3) Helment should be always worn while riding.
- 4) Walking bike is not suitable for use on public highways.
- 5) Parent/Guardian must explain to child how to use the bike.
- 6) **WARNING!** The age of use is 12 to 36 months.
- 7) The walking bike requires regular periodical inspection.
- 8) In case of any damage found immediately stop using the toy.
- 9) Store the walking bike in dry place. In case it gets wet, clean the walking bike thoroughly using dry cloth in order to prevent corrosion.
- 10) Do not allow your child to ride on stairs, public roads, and steep slopes or in the vicinity of deep holes in the ground or swimming pools, ponds, or any other body of water.
- 11) Maximum weight is 44lbs (20kg)
- 12) Never leave your child unattended.

Scan the QR code to register your product  
<https://dreamonme.com/customercare/registration/>



Dream On Me Inc.  
1532 South Washington Ave, Piscataway TWP NJ 08854  
Email: info@dreamonme.com  
www.dreamonme.com  
Item No.: #363  
MADE IN CI XI, ZHE JIANG, CHINA

## MANUAL DE INSTRUCCIÓN WB0601

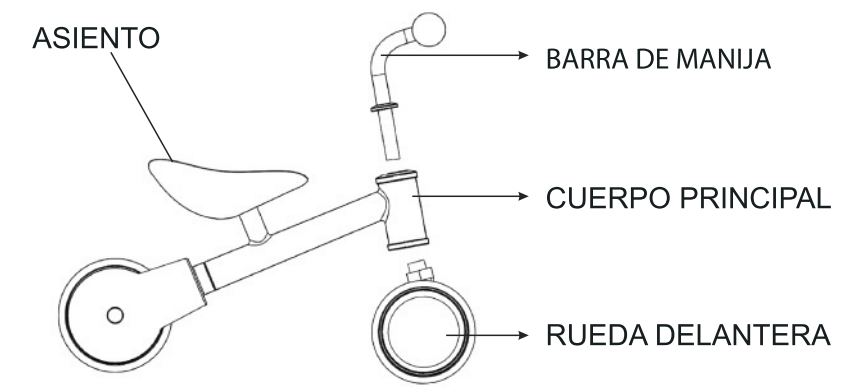

## INSTRUCCIONES DE MONTAJE

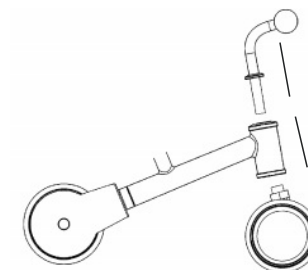

PASO 1

1. INSTALE LA BARRA DE LA MANIJA Y LA RUEDA DELANTERA EN EL CUERPO PRINCIPAL COMO PASO 1

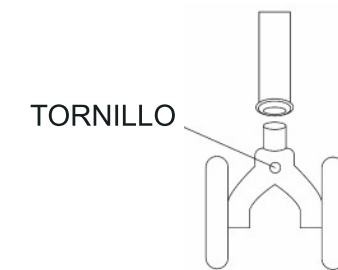

PASO 2

2. PRESTE ATENCIÓN EN LA DIRECCIÓN DE LA HORQUILLA DELANTERA, EL TORNILLO ESTÁ EN PARTE DELANTERA COMO PASO 2

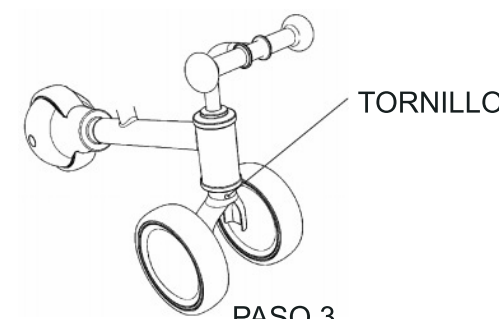

PASO 3

3. FIJE EL TORNILLO CON UNA LLAVE HEXAGONAL INTERIOR.

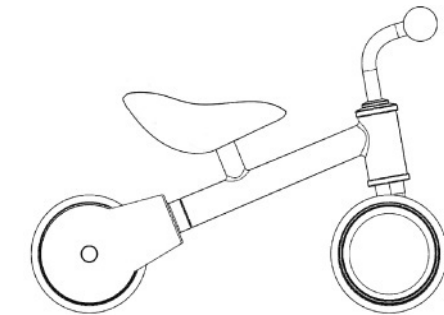

PASO 4

4. INSERTE LA SILLA Y FIJE EL TORNILLO CON UNA LLAVE HEXAGONAL INTERIOR

**¡ADVERTENCIA!** equipo de protección debe ser usado. No debe utilizarse en el tráfico.

- 1) La bicicleta debe ser montada solo por adultos.
- 2) Antes de usar, asegúrese de que la bicicleta esté correctamente ensamblada.
- 3) El casco siempre se debe usar mientras se conduce.
- 4) La bicicleta no es adecuada para el uso en autopistas públicas.
- 5) Los padres, el tutor le explicarán al niño cómo usar la bicicleta de juguete.
- 6) **ADVERTENCIA!** La edad de uso para el niño es de 12 a 36 meses.
- 7) La bicicleta para caminar requiere una inspección periódica.
- 8) En caso de cualquier daño encontrado inmediatamente, deje de usar el juguete.
- 9) Guarde la bicicleta en lugar seco. En caso de que se moje, limpie la bicicleta con un paño seco para evitar la corrosión.
- 10) No permita que su hijo viaje en escaleras, caminos públicos y en pendientes pronunciadas o en las proximidades de lugares profundos en el suelo o en piscinas, estanques o cualquier otro cuerpo de agua.
- 11) La carga máxima permitida es de 20 kg.
- 12) Nunca deje a su hijo desatendido.



1532, S. Washington Avenue  
Piscataway, NJ 08854  
E-mail: [info@dreamonme.com](mailto:info@dreamonme.com)

[www.dreamonme.com](http://www.dreamonme.com)

Follow us on



[@dreamonmeinc](https://www.facebook.com/dreamonmeinc)



[@dreamonmeinc](https://www.instagram.com/dreamonmeinc)

to get your nursery featured on our social media.

Enter our monthly giveaway!

Simply scan the QRcode to register.



Chat with us!

For any questions or concerns or feedback.

